

The most suitable HiPLE-ACE® for heavy duty packaging

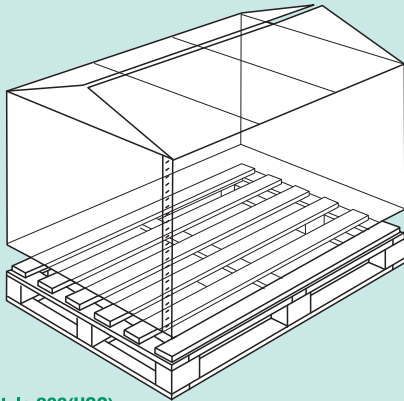

HiPLE-ACE® is the best fitting packaging material for industrial applications. Here are a few examples of HiPLE-ACE® designed by our packaging engineer. These forms represent typical design of the HiPLE-ACE® which is of greater strength but less cost. In addition, other optional forms can be designed according to the requirements of each and every customer at any time.



■ Style 200(HSC)

The attached pallet can accept the claws of forklift from all four angles

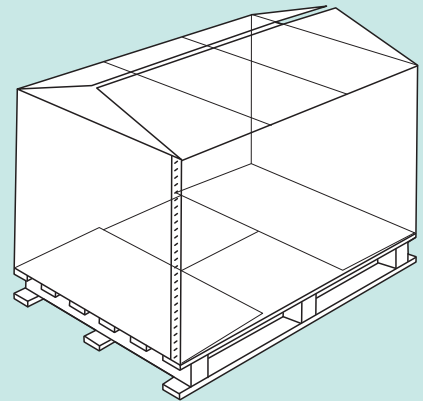

■ Style 201(RSC)

The accessory pallet is double wings type

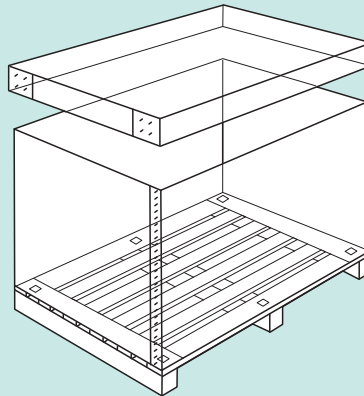

■ Style 911(ST)

Cap stitched at four corners

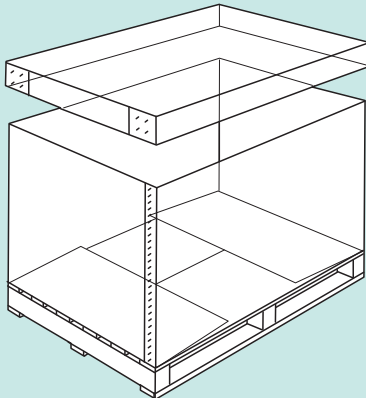

■ Style 312(SCHS)

Combination of HSC and ST

■ Style 216(SLV/F)

Sleeve with short flap at the bottom

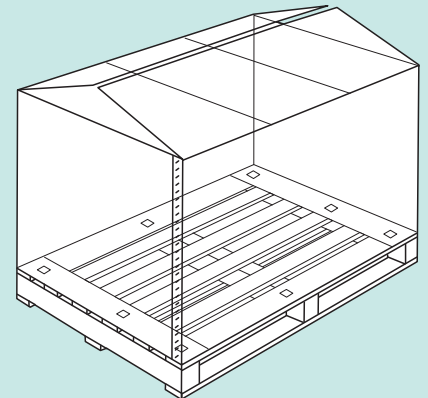

■ Style 207(HSC/SF)

HSC with short flap at the bottom

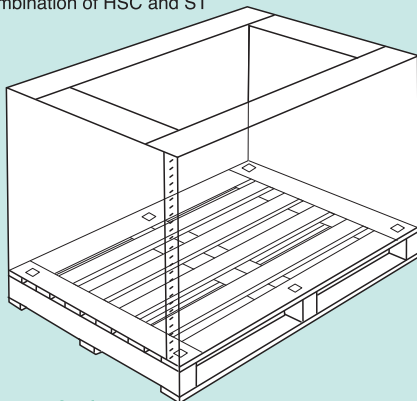

■ Style 217(SLV/TBF)

Sleeve with short flap at the top and bottom

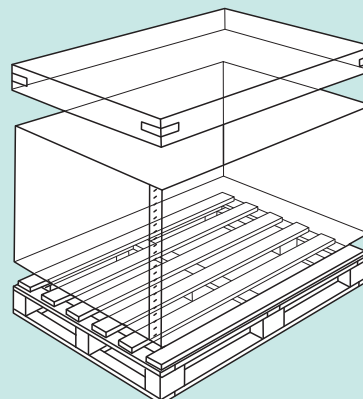

■ Style 912(CCT)

Cap taped at the four corners

■ Style 501(SLV)

Sleeve

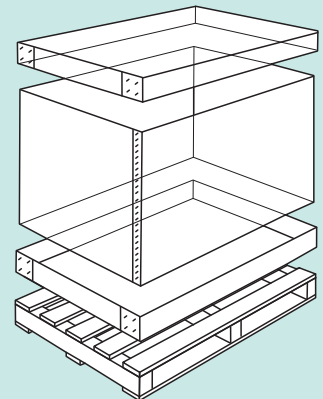

■ Style 310(DDC)

Combination of SLV and upper and lower ST

The most suitable HiPLE-ACE® for heavy duty packaging



Speciality

Special slot for easy folding

V-Notch

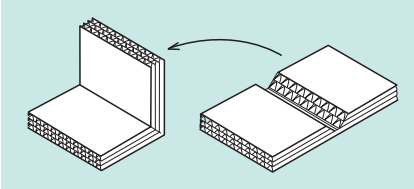

S-Cut

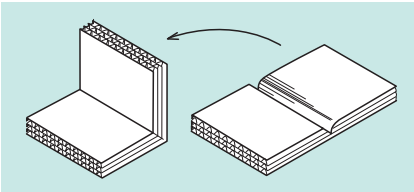

Accessories

Metal Fastener

Screw lock for HiPLE-ACE®

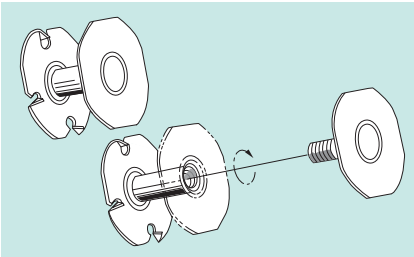

Spring Fastener

Spring lock for HiPLE-ACE®

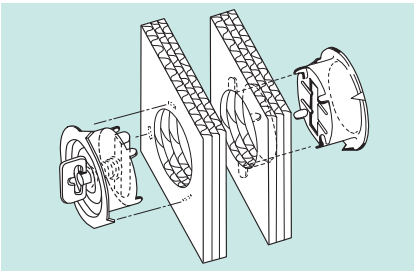

HiPLE-ACE® Nail

Nails used to fix the HiPLE-ACE® and palette

HiPLE-ACE® Clip

The cover used for the ordinary nail and tap screw when fixing the square timber

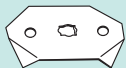
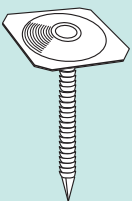

Style 321 (MOS)

Octagon of HiPLE-ACE®
No bulging against extreme pressure

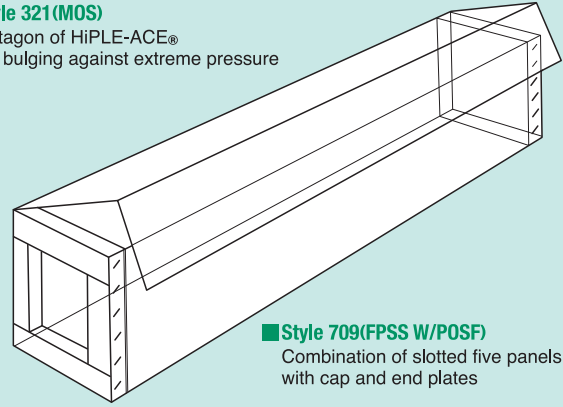
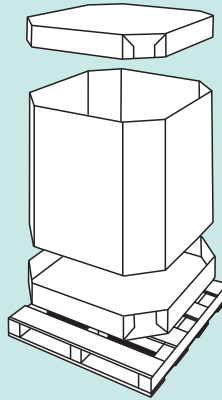

Style 709 (FPSS W/POSF)

Combination of slotted five panels
with cap and end plates

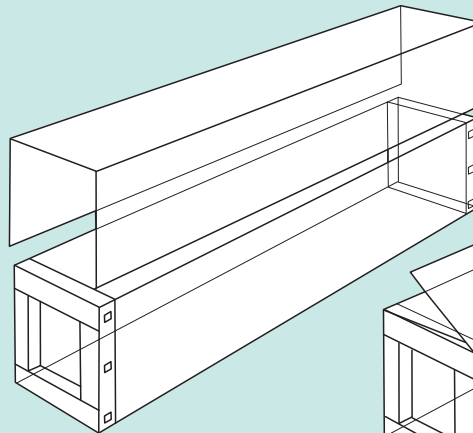

Style 702 (TPSS/FT)

Combination of two slotted
three-panels and end plates

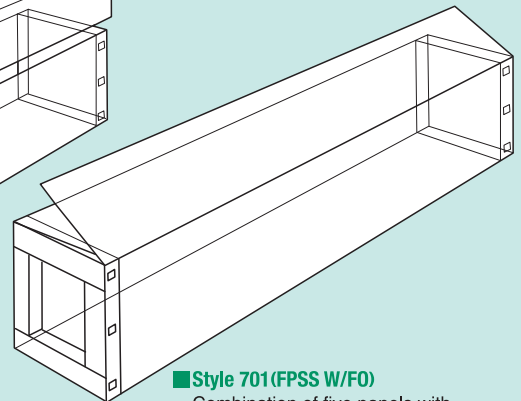

Style 701 (FPSS W/FO)

Combination of five panels with
double caps and end plates

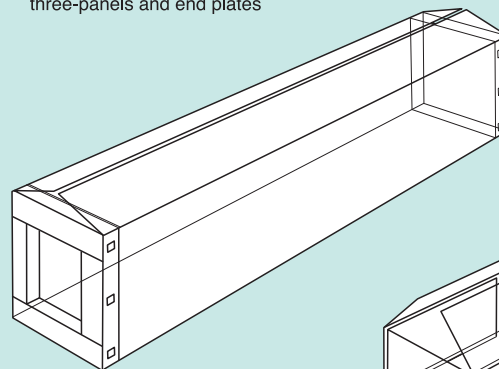

Style 705 (FPSS W/BTF)

Combination of five panels with two
half caps on the top and end plates

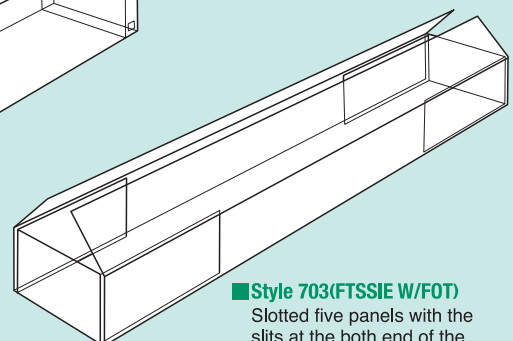

Style 703 (FTSSIE W/FOT)

Slotted five panels with the
slits at the both end of the
carton for easier folding
toward inside

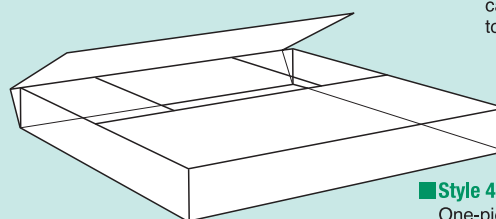

Style 401 (OPF)

One-piece folder

